

μ-Gard® Digital Transmitter

DESCRIPTION

Digital transmitter with serial interface and integrated CO sensor for the carbon monoxide detection. The additional 4 - 20 mA input (option) allows the connection of analog gas transmitters.

The communication to the Digital Gas Controller is done via the serial RS 485 interface (Modbus optional).

Commissioning is confined to setting the transmitter address via a service tool.

Comfortable calibration is also carried out with a service tool without any further special tool.



APPLICATION

The Digital Gas Transmitter MD is used for the monitoring of the ambient air to detect carbon monoxide gases in order to protect health. The analog input enables the low-cost monitoring of other gases, like e.g. NO₂ or LPG, at the measuring point. The transmitter is used for example in underground garages, engine repair shops, loading bays, tunnels, engine test stations, shelters, go-kart tracks etc.

FEATURES

- Continuous monitoring
- Low zero-point drift
- Long-life sensor (UL certification 2075)
- Easy maintenance/ calibration
- Temperature compensation
- Reverse polarity protected
- Overload protected and short-circuit protection
- Serial 4-wire bus (standard)
- One 4 – 20 mA input for external analog transmitters (option)
- Stainless steel housing (option)
- Approved according to EN 61010-1; ANSI/UL 61010 1; CAN/CSA-C22.2 No. 61010-1



WIRING CONFIGURATION

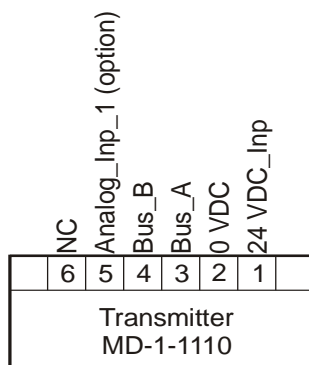

SPECIFICATIONS

Electrical

Power supply	15 - 28 V DC reverse polarity protected
Power consumption (without external transmitter)	10 mA (0.24 W)
Analog Input	4 to 20 mA, overload and short-circuit protected, input resistor 200 Ω
Power supply for external transmitter	24 V DC, max. charge 50 mA

Sensor Performance

Detected gas	Carbon monoxide (CO)	
Sensor element	Electrochemical, diffusion	
Measuring range	0 – 300 ppm	
Accuracy	± 3 ppm	
Repeatability	± 3 % of reading	
Long term zero-point drift	< 5% signal loss / year	
Response time	t ₉₀ ≤ 50 s	
Sensor life expectancy	5 years/ normal operating environment	
Mounting height	1.5 to 1.8 m (5 to 6 ft.)	
Sensor reach	465 to 930 m ² under best conditions	
Cross sensitivity*	Concentration (ppm)	Reaction (ppm CO)
Acetone, C ₃ H ₆ O	1000	0
Acetylene, C ₂ H ₂	40	80
Ammonia, NH ₃	100	0
Chlorine, Cl ₂	2	0
Ethanol, C ₂ H ₅ OH	2000	5
Iso Propanol, C ₃ H ₈ O	200	0
Carbon dioxide, CO ₂	5000	0
Nitrogen dioxide, NO ₂	50	- 1,0
Nitrogen oxide, NO	50	8
Sulphur dioxide, SO ₂	50	< 0.5
Hydrogen, H ₂	100	20

Environmental conditions

Humidity range - continuous	15 – 90 % RH, non condensing
- short-time	0 – 99 % RH, not condensing
Working temperature - continuous	-10 °C to + 50 °C (14 °F to 122 °F)
- short-time	-20 °C to + 50 °C (-4 °F to 122 °F)
Pressure range	Atmospheric ±10%
Storage temperature	5 °C to + 40 °C (41 °F to 104 °F)
Storage time	6 months

Communication

Transceiver	RS 485 / 19200 Baud
-------------	---------------------

* The table doesn't claim to be complete. Other gases, too, can have an influence on the sensitivity. The mentioned cross sensitivity data are only reference values valid for new sensors.

GAS ALARM SYSTEMS

Physical characteristics		
Enclosure	Type A and B	Type 5
Enclosure material	Polycarbonate	V2A, 1mm, material 1.4301
Flammability	UL 94 V2	
Enclosure color*	RAL 7032 (light grey)	Natural, brushed
Dimensions (W x H x D)	94 x 130 x 57 mm (3.7 x 5.12 x 2.24 inch.)	113 x 135 x 45 mm (4.45 x 5.31 x 1.77 inch.)
Weight	Approx. 0.3 kg (0.66 lbs.)	Approx. 0.5 kg (1.1 lbs.)
Protection class	IP 65	IP 55
Installation	Wall or pillar mounting, duct mounting as option	
Cable entry	Standard 1 x M 20	
Wire connection	Screw type terminal, min. 0.25 mm ² (24 AWG) max. 2.5 mm ² (14 AWG)	
Approvals/Listings	EMC Directives 2004/108/EC EN 61010-1:2010 ANSI/UL 61010-1 CAN/CSA-C22.2 No. 61010-1 CE	
Certificates	VDI 2053, Air Treatment Systems for Garages and Tunnels (in preparation)	
Sensor certification	UL recognized	
Warranty	One year on material (without sensor)	

ORDERING INFORMATION

MD-1-11XX-X-XXXX

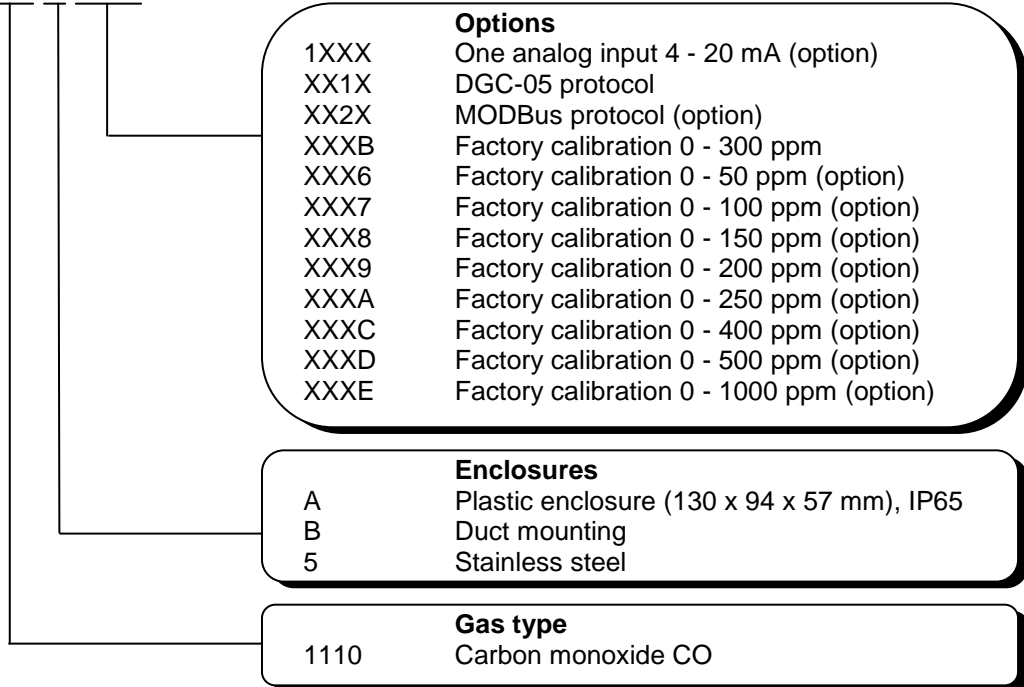

Example: Transmitter for CO detection, plastic enclosure, 1 x analog input, DGC-05 protocol, factory calibration 300 ppm

Order Number: MD-1-1110-A-101B